



PERMALOC
PERMASTRIP
 L-SHAPED MAINTENANCE STRIP

PERMALOC CORPORATION, 13505 BARRY STREET HOLLAND, MI, 49424
 (800) 356-9660 PHONE: (616) 399-9600 fax: (616) 399-9770 WWW.PERMALOC.COM

ARCHITECT NOTE: CHECK OFF APPLICABLE SIZE & FINISH DESIRED

SIZE:

- 1/8" X 3 1/2" (3.2 MM x 89 MM), 0.060" (1.52 MM) THICK
 W/ 0.200" (5.08 MM) EXPOSED TOP LIP
- 3/16" X 3 1/2" (4.8 MM x 89 MM), 0.076" (1.93 MM) THICK
 W/ 0.200" (4.83 MM) EXPOSED TOP LIP

FINISH LEGEND:

- (MF) MILL FINISH-NATURAL ALUMINUM
- (BL) BLACK DURAFLEX-ELECTROSTATICALLY APPLIED
 BAKED ON PAINT, MEETS AAMA 2603

NOTES:

1. INSTALL PER MANUFACTURER'S "INSTALLATION GUIDELINES"
2. 8'-0" (2.44 M) SECTIONS TO INCLUDE (3) 12" (305 MM) ALUMINUM STAKES.
3. 16'-0" (4.88 M) SECTIONS TO INCLUDE (8) 12" (305 MM) ALUMINUM STAKES.
4. CORNERS: NOTCH BASE ONLY AND FORM A CONTINUOUS CORNER.
5. PERMALOC PERMASTRIP AS MANUFACTURED BY PERMALOC CORPORATION, HOLLAND MI. (800) 356-9660, (616) 399-9600
6. CONTRACTOR'S NOTE: FOR PRODUCT AND PURCHASING INFORMATION VISIT: WWW.PERMALOC.COM

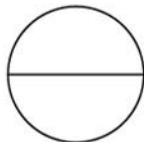
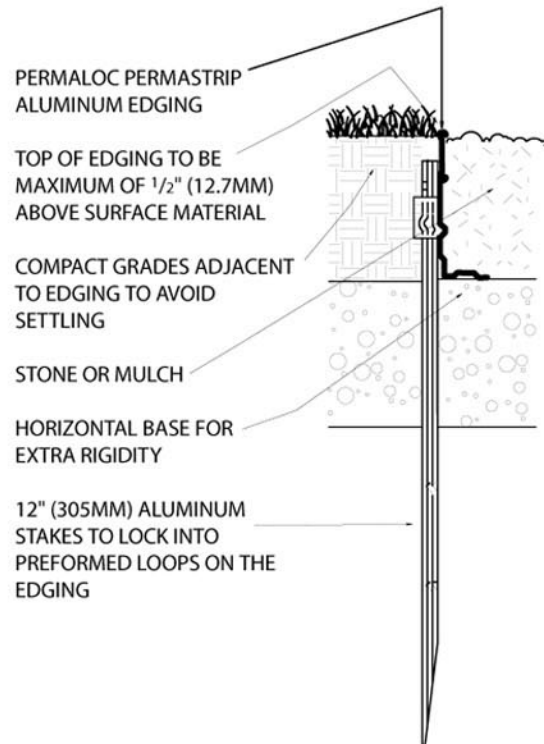
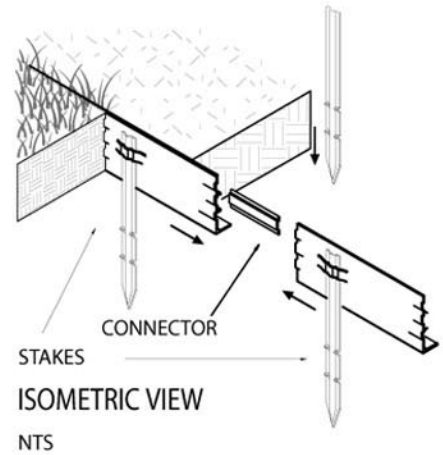

EDGE DETAIL-STONE/MULCH MAINTENANCE STRIP

SCALE: 3"=1'-0"